

COMBO DOOR PASS-THRU LABORATORY/PHARMACY FREEZERS

Project Name:

Model Specified:

Location:

Item No:

Quantity:

Continental

SCIENTIFIC

539 Dunksferry Road
Bensalem, PA 19020
www.continentalscientific.com

Toll-Free: 800-523-7138
Phone: 215-244-1400
Fax: 215-244-9579

S1FXNGDPT



Standard Model Features

REFRIGERATION SYSTEM

- Stainless steel front, aluminum end panels & interior
- Self contained, performance-rated refrigeration system
- Natural, environmentally-safe, high-efficiency R-290 refrigerant (S1FXNGDPT)
- Environmentally-safe R-448a refrigerant (S2F-GD-PT)
- Automatic, hot gas condensate evaporator
- Automatic electric defrost

CABINET ARCHITECTURE

- 3" Non-CFC polyurethane foamed-in-place insulation
- Chrome-plated handles
- Heavy-duty epoxy-coated steel shelves
- Cylinder lock in each door
- Magnetic snap-in door gaskets
- (1) 1/2" diameter probe access ports
- Attached 10 ft. cord & 90° hospital grade NEMA-5-15P plug
- Adjustable temperature control, range -22°C to -12°C, factory pre-set at -20°C
- 5" Casters

MODEL FEATURES

- LED interior lighting
- Glass door on one side, solid door on the other side
- Electronic controller w/ centigrade temperature digital display

S2F-GD-PT



Options and Accessories

(upcharges and lead times may apply)

Adjustable legs	220/50/1 Voltage
Additional shelves	208-230/60/1 Voltage
Rehinging of doors	7 Day temperature chart recorder
Half doors (-HD models)	Remote temperature logger
Stainless steel exterior, aluminum interior (-SA models)	Audible/visual temperature alarm w/ battery back-up & dry contact relay
Stainless steel exterior and interior (-SS models)	Export crating
NIST thermometer (consult factory)	

APPROVAL:

COMBO DOOR PASS-THRU LABORATORY/PHARMACY FREEZERS

Line Drawings

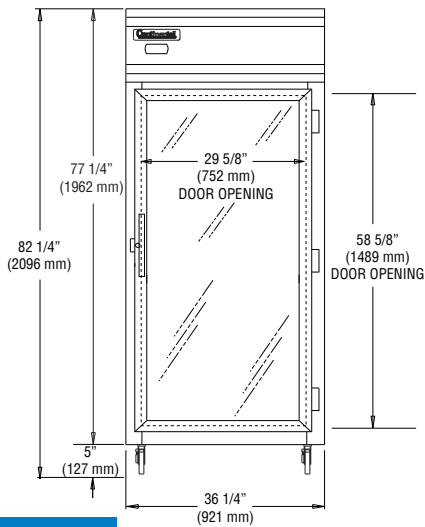

S1FXNGDPT Front View

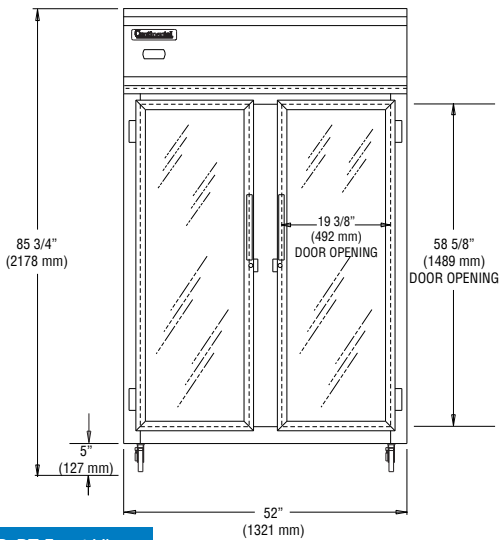

S2F-GD-PT Front View

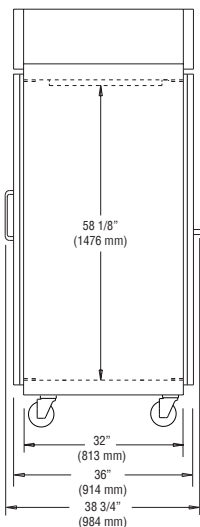

Side View (all)

Continental

SCIENTIFIC

539 Dunksferry Road
Bensalem, PA 19020

www.continentalscientific.com

Toll-Free: 800-523-7138
Phone: 215-244-1400
Fax: 215-244-9579

Model Specifications

DIMENSIONAL DATA

	S1FXNGDPT	S2F-GD-PT
Net Capacity (cu. ft.)	30	48
Width, Overall (in.)	36 1/4	52
Depth, Overall (in.) (incl. handles & bumpers)	38 3/4	38 3/4
Height, Overall (in.)	82 1/4	82 1/4
No. of Doors	2	4
No. of Shelves	4	8

REFRIGERATION DATA

Condensing Unit (H.P.)	1	3/4
------------------------	---	-----

ELECTRICAL DATA

Voltage	115/60/1	115/208-230/60/1
Feed Wires (incl. ground)	3	4
Total Amps	10.6	11.9
10 ft. Cord/Plug [attached]	Yes	No

SHIPPING DATA

Weight (lbs.)	450	665
Height - Crated (in.)	85 1/2	85 1/2
Width - Crated (in.)	42	64
Depth - Crated (in.)	42	42

Ship Weight for -SA and -SS models is on average 5% higher than Standard models. Consult factory for shipping weight of these models.



Equipped with (1) 90° hospital grade NEMA-5-15P plug (varies by country)
For S1FXN Only

LOCATION OF 1/2" DIAMETER PROBE ACCESS PORT:

(1) Ceiling, front top left corner

Consult factory for exact locations

Due to our continued efforts in developing innovative products, specifications subject to change without notice.

© Copyright 2021. Continental Refrigerator.
A Division of National Refrigeration & Air Conditioning Products, Inc.

