

SOLID DOOR LABORATORY/PHARMACY REFRIGERATORS

Project Name:

Model Specified:

Location:

Item No:

Quantity:

Continental

SCIENTIFIC

539 Dunksferry Road
Bensalem, PA 19020
www.continentalscientific.com

Toll-Free: 800-523-7138
Phone: 215-244-1400
Fax: 215-244-9579

S1RN



**COMPLIES WITH CDC & VFC (VACCINES FOR CHILDREN)
RECOMMENDED GUIDELINES FOR VACCINE STORAGE**

S2RN



**COMPLIES WITH CDC & VFC (VACCINES FOR CHILDREN)
RECOMMENDED GUIDELINES FOR VACCINE STORAGE**

S3RN



Standard Model Features

REFRIGERATION SYSTEM

- Stainless steel front, aluminum end panels & interior
- Self contained, performance-rated refrigeration system
- Natural, environmentally-safe, high-efficiency R-290 refrigerant
- Expansion valve system
- Automatic, electric condensate evaporator

CABINET ARCHITECTURE

- 3" Non-CFC polyurethane foamed-in-place insulation
- Smooth, polished workflow chrome door handles
- Heavy-duty epoxy-coated steel shelves
- Cylinder lock in door
- Magnetic snap-in Santoprene™ door gaskets
- (2) 1/2" diameter access ports
- Attached 10 ft. cord & 90° hospital grade NEMA-5-15P plug
- Adjustable temperature control, range +2°C - +8°C, factory pre-set at +4°C
- 5" Casters

MODEL FEATURES

- LED interior lighting
- Electronic controller w/ centigrade temperature digital display

Options and Accessories

(upcharges and lead times may apply)

Adjustable legs	220/50/1 Voltage
Additional shelves	208-230/60/1 Voltage
Pass thru doors (-PT models)	7 Day temperature chart recorder
Rehinging of doors	Remote temperature logger
Half doors (-HD models)	Audible/visual temperature alarm w/ battery back-up & dry contact relay
Stainless steel exterior, aluminum interior (-SA models)	Export crating
Stainless steel exterior and interior (-SS models)	NIST thermometer (consult factory)

APPROVAL:

SOLID DOOR LABORATORY/PHARMACY REFRIGERATORS

Line Drawings

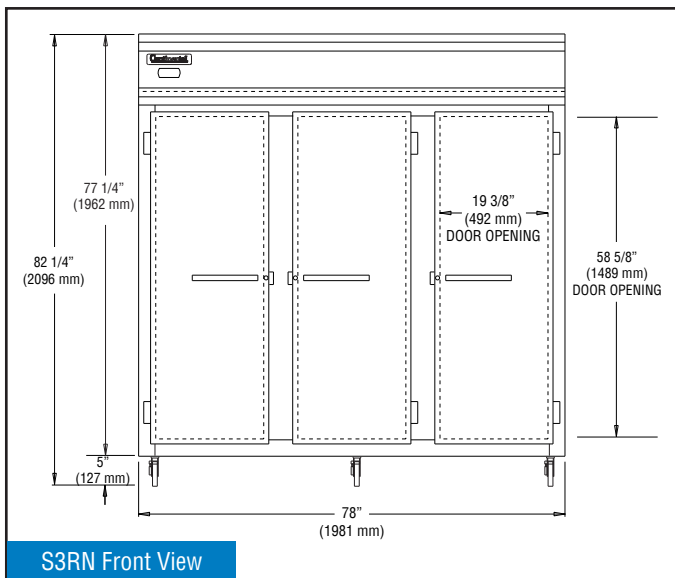
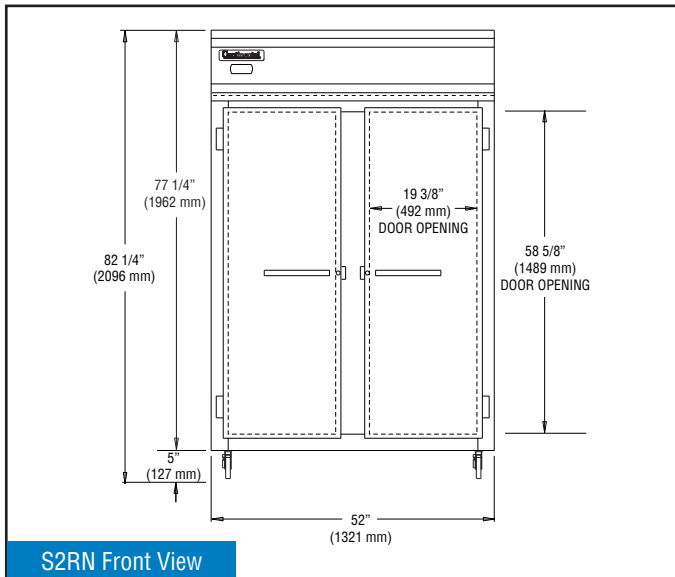
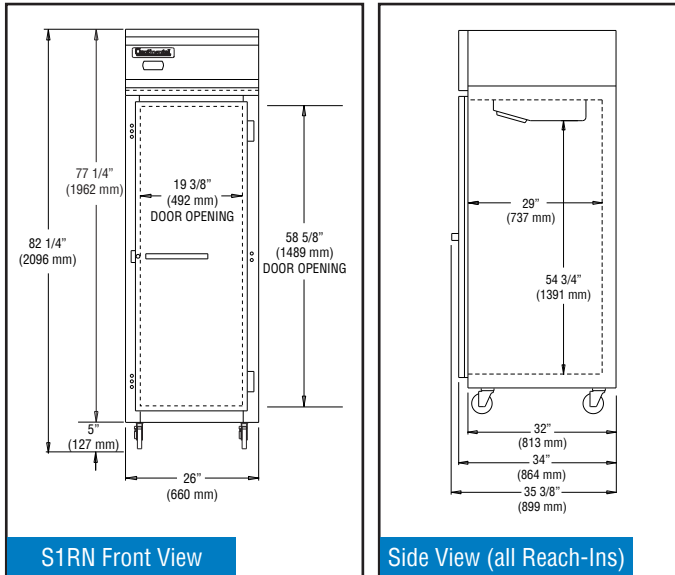

Continental

SCIENTIFIC

539 Dunksferry Road
Bensalem, PA 19020
www.continentalscientific.com

Toll-Free: 800-523-7138
Phone: 215-244-1400
Fax: 215-244-9579

Model Specifications

DIMENSIONAL DATA	S1RN	S2RN	S3RN
Net Capacity (cu. ft.)	20	48	70
Width, Overall (in.)	26	52	78
Depth, Overall (in.) (incl. handles & bumpers)	35 3/8	35 3/8	35 3/8
Height, Overall (in.)	82 1/4	82 1/4	82 1/4
No. of Doors	1	2	3
No. of Shelves	4	8	12
REFRIGERATION DATA			
Condensing Unit (H.P.)	1/4+	1/3+	1/2
ELECTRICAL DATA			
Voltage	115/60/1	115/60/1	115/60/1
Feed Wires (incl. ground)	3	3	3
Total Amps	5.2	6.9	8.5
10 ft. Cord/Plug [attached]	Yes	Yes	Yes
SHIPPING DATA			
Weight (lbs.)	284	433	619
Height - Crated (in.)	85 1/2	85 1/2	85 1/2
Width - Crated (in.)	31 5/8	64	90
Depth - Crated (in.)	42	42	42

Ship Weight for -SA and -SS models is on average 5% higher than Standard models. Consult factory for shipping weight of these models.



Equipped with (1) 90° hospital grade NEMA-5-15P plug (varies by country)

LOCATION OF 1/2" DIAMETER PROBE ACCESS PORTS:

- (1) Ceiling, front top left corner
- (1) Rear wall, top center

Consult factory for exact locations

Due to our continued efforts in developing innovative products, specifications subject to change without notice.

© Copyright 2021. Continental Refrigerator.
A Division of National Refrigeration & Air Conditioning Products, Inc.



EXTRA WIDE SOLID DOOR LABORATORY/PHARMACY REFRIGERATORS

Project Name:

Model Specified:

Location:

Item No:

Quantity:

Continental

SCIENTIFIC

539 Dunksferry Road
Bensalem, PA 19020
www.continentalscientific.com

Toll-Free: 800-523-7138
Phone: 215-244-1400
Fax: 215-244-9579

S1RXN



Standard Model Features

REFRIGERATION SYSTEM

- Stainless steel front, aluminum end panels & interior
- Self contained, performance-rated refrigeration system
- Natural, environmentally-safe, high-efficiency R-290 refrigerant
- Expansion valve system
- Automatic, electric condensate evaporator

CABINET ARCHITECTURE

- 3" Non-CFC polyurethane foamed-in-place insulation
- Smooth, polished workflow chrome door handles
- Heavy-duty epoxy-coated steel shelves
- Cylinder lock in door
- Magnetic snap-in Santoprene™ door gaskets
- (2) 1/2" diameter access ports
- Attached 10 ft. cord & 90° hospital grade NEMA-5-15P plug
- Adjustable temperature control, range +2°C - +8°C, factory pre-set at +4°C
- 5" Casters

MODEL FEATURES

- LED interior lighting
- Electronic controller w/ centigrade temperature digital display

Options and Accessories

(upcharges and lead times may apply)

Adjustable legs	220/50/1 Voltage
Additional shelves	208-230/60/1 Voltage
Pass thru doors (-PT models)	7 Day temperature chart recorder
Rehinging of doors	Remote temperature logger
Half doors (-HD models)	Audible/visual temperature alarm w/ battery back-up & dry contact relay
Stainless steel exterior, aluminum interior (-SA models)	Export crating
Stainless steel exterior and interior (-SS models)	NIST thermometer (consult factory)

APPROVAL:

EXTRA WIDE SOLID DOOR LABORATORY/PHARMACY REFRIGERATORS

Line Drawings

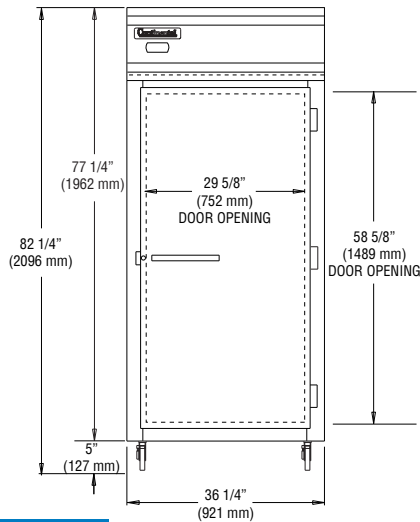

S1RXN Front View

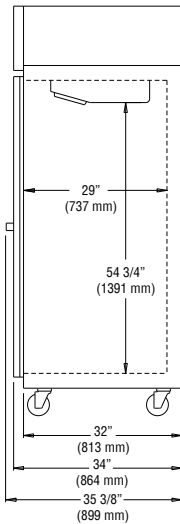

S1RXN Side View

Continental

SCIENTIFIC

539 Dunksferry Road
Bensalem, PA 19020
www.continentalscientific.com

Toll-Free: 800-523-7138
Phone: 215-244-1400
Fax: 215-244-9579

Model Specifications

DIMENSIONAL DATA	S1RXN
Net Capacity (cu. ft.)	30
Width, Overall (in.)	36 1/4
Depth, Overall (in.) (incl. handles & bumpers)	35 3/8
Height, Overall (in.)	82 1/4
No. of Doors	1
No. of Shelves	4
REFRIGERATION DATA	
Condensing Unit (H.P.)	1/3+
ELECTRICAL DATA	
Voltage	115-60-1
Feed Wires (incl. ground)	3
Total Amps	6.6
10 ft. Cord/Plug [attached]	Yes
SHIPPING DATA	
Weight (lbs.)	430
Height - Crated (in.)	85 1/2
Width - Crated (in.)	42
Depth - Crated (in.)	42

Ship Weight for -SA and -SS models is on average 5% higher than Standard models. Consult factory for shipping weight of these models.



Equipped with (1) 90° hospital grade NEMA-5-15P plug (varies by country)

LOCATION OF 1/2" DIAMETER PROBE ACCESS PORTS:

- (1) Ceiling, front top left corner
- (1) Rear wall, top center

Consult factory for exact locations

Due to our continued efforts in developing innovative products, specifications subject to change without notice.

© Copyright 2021. Continental Refrigerator.
A Division of National Refrigeration & Air Conditioning Products, Inc.

