

# SOLID DOOR LABORATORY/PHARMACY FREEZERS

Project Name:

Model Specified:

Location:

Item No:

Quantity:

# Continental

SCIENTIFIC

539 Dunksferry Road  
Bensalem, PA 19020  
[www.continentalscientific.com](http://www.continentalscientific.com)

Toll-Free: 800-523-7138  
Phone: 215-244-1400  
Fax: 215-244-9579

S1FN



**COMPLIES WITH CDC & VFC (VACCINES FOR CHILDREN)  
RECOMMENDED GUIDELINES FOR VACCINE STORAGE**

S2FN



**COMPLIES WITH CDC & VFC (VACCINES FOR CHILDREN)  
RECOMMENDED GUIDELINES FOR VACCINE STORAGE**

S3FN



## Standard Model Features

### REFRIGERATION SYSTEM

- Stainless steel front, aluminum end panels & interior
- Self contained, performance-rated refrigeration system
- Natural, environmentally-safe, high-efficiency R-290 refrigerant
- Automatic, electric condensate evaporator
- Automatic electric defrost

### CABINET ARCHITECTURE

- 3" Non-CFC polyurethane foamed-in-place insulation
- Smooth, polished workflow chrome door handles
- Heavy-duty epoxy-coated steel shelves
- Cylinder lock in door
- Magnetic snap-in Santoprene™ door gaskets
- (2) 1/2" diameter access ports
- Attached 10 ft. cord & 90° hospital grade NEMA-5-15P plug
- Adjustable temperature control, range -22°C to -12°C, factory pre-set at -20°C
- 5" Casters

### MODEL FEATURES

- LED interior lighting
- Electronic controller w/ centigrade temperature digital display

## Options and Accessories

(upcharges and lead times may apply)

Adjustable legs	220/50/1 Voltage
Additional shelves	208-230/60/1 Voltage
Pass thru doors (-PT models)	7 Day temperature chart recorder
Rehinging of doors	Remote temperature logger
Half doors (-HD models)	Audible/visual temperature alarm w/ battery back-up & dry contact relay
Stainless steel exterior, aluminum interior (-SA models)	Export crating
Stainless steel exterior and interior (-SS models)	NIST thermometer (consult factory)

APPROVAL:

# SOLID DOOR LABORATORY/PHARMACY FREEZERS

## Line Drawings

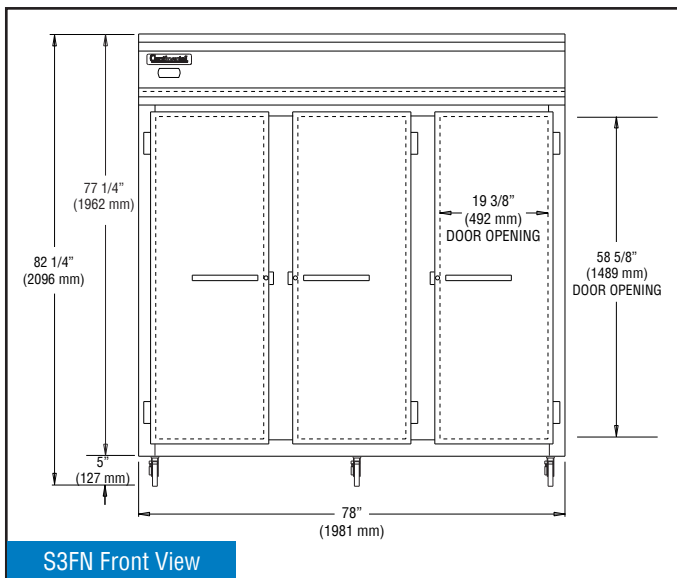
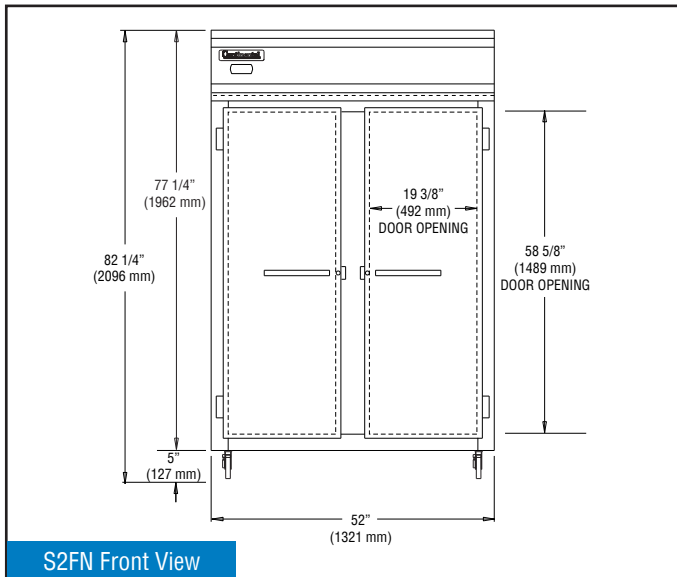
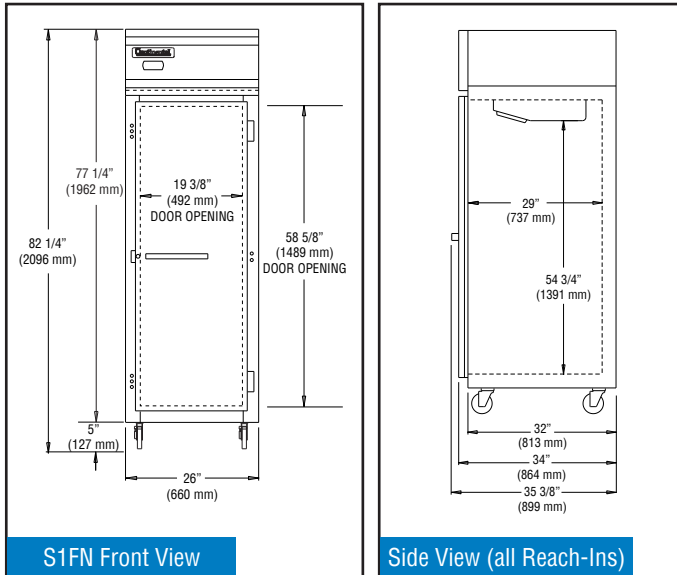

# Continental

## SCIENTIFIC

539 Dunksferry Road  
Bensalem, PA 19020  
[www.continentalscientific.com](http://www.continentalscientific.com)

Toll-Free: 800-523-7138  
Phone: 215-244-1400  
Fax: 215-244-9579

## Model Specifications

DIMENSIONAL DATA	S1FN	S2FN	S3FN
Net Capacity (cu. ft.)	20	48	70
Width, Overall (in.)	26	52	78
Depth, Overall (in.) (incl. handles & bumpers)	32	32	32
Height, Overall (in.)	82 1/4	82 1/4	82 1/4
No. of Doors	1	2	3
No. of Shelves	4	8	12
REFRIGERATION DATA			
Condensing Unit (H.P.)	1/3	1/2	1
ELECTRICAL DATA			
Voltage	115/60/1	115/60/1	115/208-230/60/1
Feed Wires (incl. ground)	3	3	4
Total Amps	6.3	9.8	11.9
10 ft. Cord/Plug [attached]	Yes	Yes	No
SHIPPING DATA			
Weight (lbs.)	325	555	790
Height - Crated (in.)	85 1/2	85 1/2	85 1/2
Width - Crated (in.)	31 5/8	64	90
Depth - Crated (in.)	42	42	42

**Ship Weight** for -SA and -SS models is on average 5% higher than Standard models. Consult factory for shipping weight of these models.



Equipped with (1) 90° hospital grade NEMA-5-15P plug (varies by country) (Excludes S3FN models)

### LOCATION OF 1/2" DIAMETER PROBE ACCESS PORTS:

- (1) Ceiling, front top left corner
  - (1) Rear wall, top center
- Consult factory for exact locations

Due to our continued efforts in developing innovative products, specifications subject to change without notice.

© Copyright 2021. Continental Refrigerator.  
A Division of National Refrigeration & Air Conditioning Products, Inc.



# EXTRA WIDE SOLID DOOR LABORATORY/PHARMACY FREEZERS

Project Name:

Model Specified:

Location:

Item No:

Quantity:

# Continental

## SCIENTIFIC

539 Dunksferry Road  
Bensalem, PA 19020  
[www.continentalscientific.com](http://www.continentalscientific.com)

Toll-Free: 800-523-7138  
Phone: 215-244-1400  
Fax: 215-244-9579

S1FXN



### Standard Model Features

#### REFRIGERATION SYSTEM

- Stainless steel front, aluminum end panels & interior
- Self contained, performance-rated refrigeration system
- Natural, environmentally-safe, high-efficiency R-290 refrigerant
- Automatic, electric condensate evaporator
- Automatic electric defrost

#### CABINET ARCHITECTURE

- 3" Non-CFC polyurethane foamed-in-place insulation
- Smooth, polished workflow chrome door handles
- Heavy-duty epoxy-coated steel shelves
- Cylinder lock in door
- Magnetic snap-in Santoprene™ door gasket
- (2) 1/2" diameter probe access ports
- Attached 10 ft. cord & 90° hospital grade NEMA-5-15P plug
- Adjustable temperature control, range -22°C to -12°C, factory pre-set at -20°C
- 5" Casters

#### MODEL FEATURES

- LED interior lighting
- Electronic controller w/ centigrade temperature digital display

### Options and Accessories

(upcharges and lead times may apply)

Adjustable legs	220/50/1 Voltage
Additional shelves	208-230/60/1 Voltage
Pass thru doors (-PT models)	7 Day temperature chart recorder
Rehinging of doors	Remote temperature logger
Half doors (-HD models)	Audible/visual temperature alarm w/ battery back-up & dry contact relay
Stainless steel exterior, aluminum interior (-SA models)	Export crating
Stainless steel exterior and interior (-SS models)	NIST thermometer (consult factory)

APPROVAL:

# EXTRA WIDE SOLID DOOR LABORATORY/PHARMACY FREEZERS

## Line Drawings

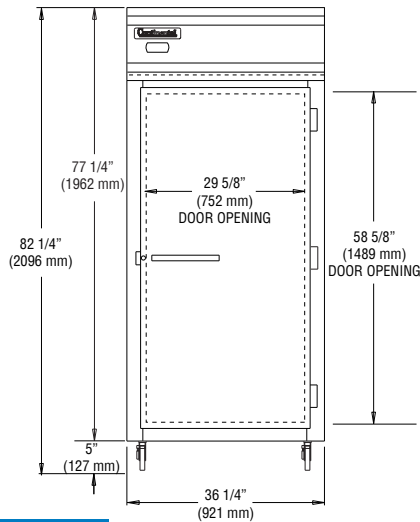

S1FXN Front View

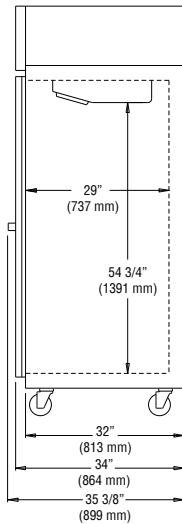

S1FXN Side View

# Continental

SCIENTIFIC

539 Dunksferry Road  
Bensalem, PA 19020

[www.continentalscientific.com](http://www.continentalscientific.com)

Toll-Free: 800-523-7138  
Phone: 215-244-1400  
Fax: 215-244-9579

## Model Specifications

### DIMENSIONAL DATA

	S1FXN
Net Capacity (cu. ft.)	30
Width, Overall (in.)	36 1/4
Depth, Overall (in.) (incl. handles & bumpers)	35 3/8
Height, Overall (in.)	82 1/4
No. of Doors	1
No. of Shelves	4

### REFRIGERATION DATA

Condensing Unit (H.P.)	1/2
Voltage	115/60/1
Feed Wires (incl. ground)	3
Total Amps	8.6
10 ft. Cord/Plug [attached]	Yes

### SHIPPING DATA

Weight (lbs.)	445
Height - Crated (in.)	85 1/2
Width - Crated (in.)	42
Depth - Crated (in.)	42

Ship Weight for -SA and -SS models is on average 5% higher than Standard models. Consult factory for shipping weight of these models.



Equipped with (1) 90° hospital grade NEMA-5-15P plug (varies by country)

### LOCATION OF 1/2" DIAMETER PROBE ACCESS PORTS:

- (1) Ceiling, front top left corner
- (1) Rear wall, top center

Consult factory for exact locations

Due to our continued efforts in developing innovative products, specifications subject to change without notice.

© Copyright 2021. Continental Refrigerator.  
A Division of National Refrigeration & Air Conditioning Products, Inc.

