

SOLID DOOR DUAL TEMP LABORATORY/PHARMACY REFRIGERATORS/FREEZERS

Project Name:

Model Specified:

Location:

Item No:

Quantity:

Continental

SCIENTIFIC

539 Dunksferry Road
Bensalem, PA 19020
www.continentalscientific.com

Toll-Free: 800-523-7138
Phone: 215-244-1400
Fax: 215-244-9579

S1RFN



Standard Model Features

REFRIGERATION SYSTEM

- Stainless steel front, aluminum end panels & interior
- Self contained, performance-rated refrigeration system
- Natural, environmentally-safe, high-efficiency R-290 refrigerant
- Automatic, electric condensate evaporator
- Automatic electric defrost (freezer section)

CABINET ARCHITECTURE

- 3" Non-CFC polyurethane foamed-in-place insulation
- Smooth, polished workflow chrome door handles
- Heavy-duty epoxy-coated steel shelves
- Cylinder lock in door
- Magnetic snap-in Santoprene™ door gaskets
- (2) 1/2" diameter access ports
- (2) Attached 10 ft. cord & 90° hospital grade NEMA-5-15P plug
- Adjustable temperature control, Refrigerator range: +2°C to +8°C, factory pre-set at +4°C
Freezer range: -22°C to -12°C, factory pre-set at -20°C
- 5" Casters

MODEL FEATURES

- LED interior lighting
- Electronic controller w/ centigrade temperature digital display
- Half doors (-HD models)

Options and Accessories

(upcharges and lead times may apply)

Adjustable legs	220/50/1 Voltage
Additional shelves	208-230/60/1 Voltage
Rehinging of doors	7 Day temperature chart recorder
Stainless steel exterior, aluminum interior (-SA models)	Remote temperature logger
Stainless steel exterior and interior (-SS models)	Export crating
Audible/visual temperature alarm w/ battery back-up & dry contact relay	NIST thermometer (consult factory)

APPROVAL:

SOLID DOOR DUAL TEMP LABORATORY/PHARMACY REFRIGERATORS/FREEZERS

Line Drawings

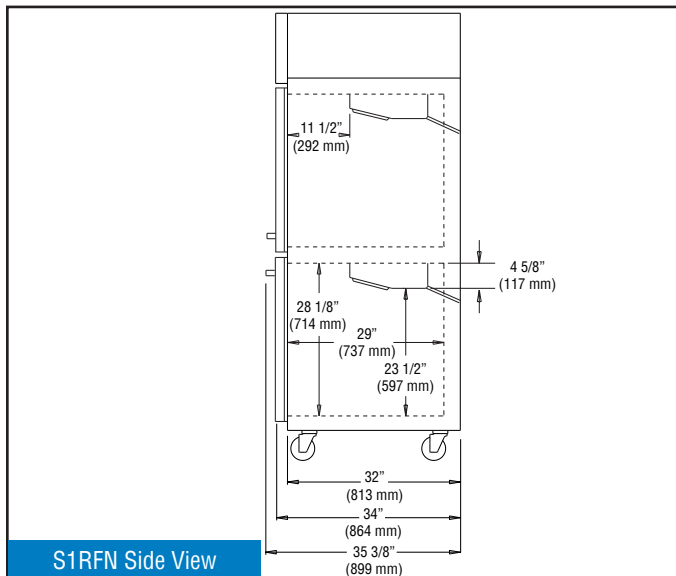
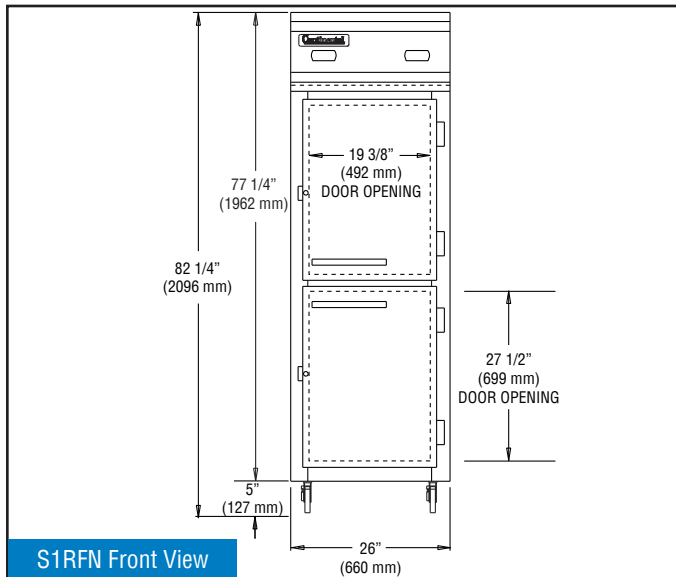

Continental

SCIENTIFIC

539 Dunksferry Road
Bensalem, PA 19020
www.continentalscientific.com

Toll-Free: 800-523-7138
Phone: 215-244-1400
Fax: 215-244-9579

Model Specifications

DIMENSIONAL DATA

	S1RFN
Net Capacity (cu. ft.)	10/10
Width, Overall (in.)	26
Depth, Overall (in.) (incl. handles & bumpers)	35 3/8
Height, Overall (in.)	82 1/4
No. of Doors	2
No. of Shelves	4

REFRIGERATION DATA

Condensing Unit (H.P.)	1/5, 1/3
------------------------	----------

ELECTRICAL DATA

Voltage	115-60-1 (220/50/1)
Feed Wires (incl. ground)	3, 3
Total Amps	2.5, 5.7
Defrost Amps	3.9
10 ft. Cord/Plug [attached]	(2) Yes (No)

SHIPPING DATA

Weight (lbs.)	420
Height - Crated (in.)	85 1/2
Width - Crated (in.)	64
Depth - Crated (in.)	42

Ship Weight for -SA and -SS models is on average 5% higher than Standard models. Consult factory for shipping weight of these models.



Equipped with (1) 90° hospital grade NEMA-5-15P plug (varies by country)

LOCATION OF 1/2" DIAMETER PROBE ACCESS PORTS:

Consult factory for exact locations

Due to our continued efforts in developing innovative products, specifications subject to change without notice.

© Copyright 2021. Continental Refrigerator.
A Division of National Refrigeration & Air Conditioning Products, Inc.



SOLID DOOR DUAL TEMP LABORATORY/PHARMACY REFRIGERATORS/FREEZERS

Project Name:

Model Specified:

Location:

Item No:

Quantity:

Continental

SCIENTIFIC

539 Dunksferry Road
Bensalem, PA 19020
www.continentalscientific.com

Toll-Free: 800-523-7138
Phone: 215-244-1400
Fax: 215-244-9579

S2RFN



Standard Model Features

REFRIGERATION SYSTEM

- Stainless steel front, aluminum end panels & interior
- Self contained, performance-rated refrigeration system
- Natural, environmentally-safe, high-efficiency R-290 refrigerant
- Automatic, electric condensate evaporator
- Automatic electric defrost (freezer section)

CABINET ARCHITECTURE

- 3" Non-CFC polyurethane foamed-in-place insulation
- Smooth, polished workflow chrome door handles
- Heavy-duty epoxy-coated steel shelves
- Cylinder lock in door
- Magnetic snap-in Santoprene™ door gaskets
- (4) 1/2" diameter access ports
- (2) Attached 10 ft. cord & 90° hospital grade NEMA-5-15P plug
- Adjustable temperature control,
Refrigerator range: +2°C to +8°C, factory pre-set at +4°C
Freezer range: -22°C to -12°C, factory pre-set at -20°C
- 5" Casters

MODEL FEATURES

- LED interior lighting
- Electronic controller w/ centigrade temperature digital display

S3RRFN



Options and Accessories

(upcharges and lead times may apply)

Adjustable legs	220/50/1 Voltage
Additional shelves	208-230/60/1 Voltage
Pass thru doors (-PT models)	7 Day temperature chart recorder
Rehinging of doors	Remote temperature logger
Half doors (-HD models)	Audible/visual temperature alarm w/ battery back-up & dry contact relay
Stainless steel exterior, aluminum interior (-SA models)	Export crating
Stainless steel exterior and interior (-SS models)	NIST thermometer (consult factory)

S3RFFN



APPROVAL:

SOLID DOOR DUAL TEMP LABORATORY/PHARMACY REFRIGERATORS/FREEZERS

Line Drawings

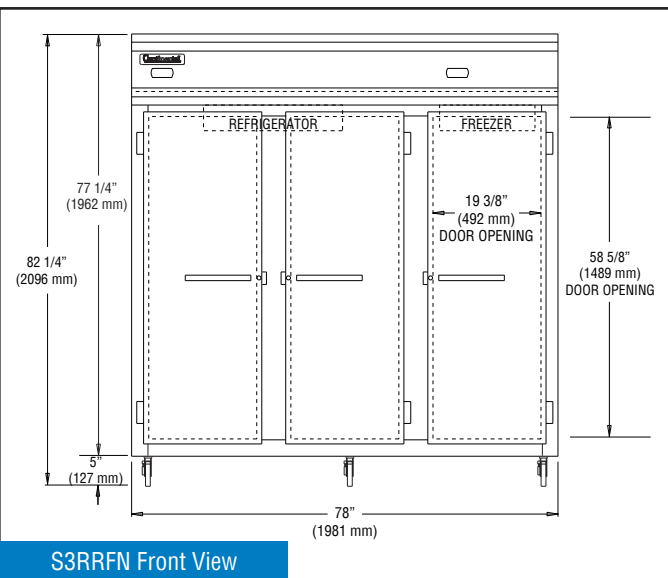
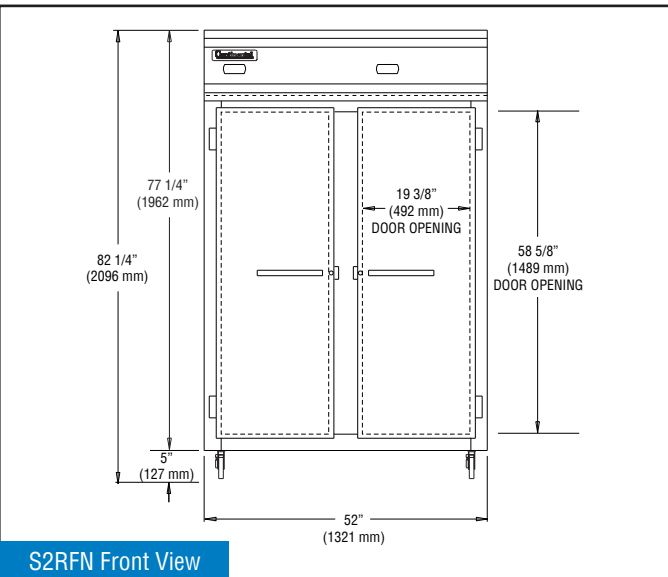
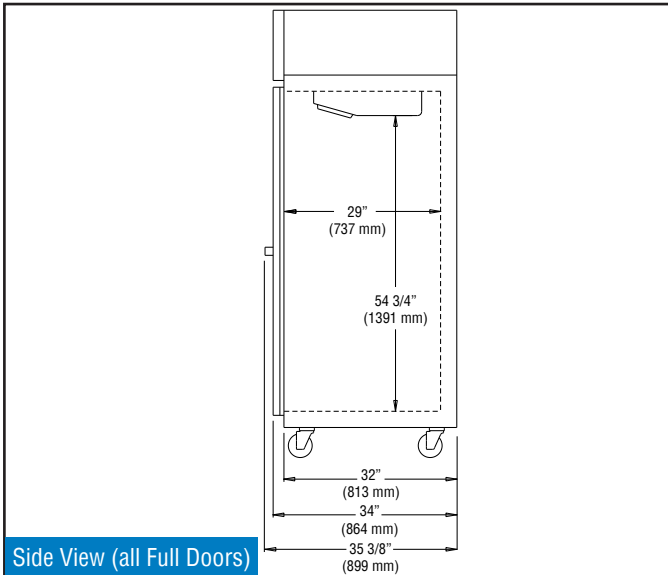

Continental

SCIENTIFIC

539 Dunksferry Road
Bensalem, PA 19020
www.continentalscientific.com

Toll-Free: 800-523-7138
Phone: 215-244-1400
Fax: 215-244-9579

Model Specifications

DIMENSIONAL DATA	S2RFN	S3RRFN	S3RFFN
Net Capacity (cu. ft.)	20/20	48/20	20/48
Width, Overall (in.)	52	78	78
Depth, Overall (in.) (incl. handles & bumpers)	35 3/8	35 3/8	35 3/8
Height, Overall (in.)	82 1/4	82 1/4	82 1/4
No. of Doors	2	3	3
No. of Shelves	8	12	12

REFRIGERATION DATA

CONDENSING UNIT (H.P.)	S2RFN	S3RRFN	S3RFFN
Condensing Unit (H.P.)	1/4+, 1/2	1/3+, 1/2	1/4, 1/2

ELECTRICAL DATA

VOLTAGE	S2RFN	S3RRFN	S3RFFN
Voltage	115-60-1	115-60-1	115-60-1
Feed Wires (incl. ground)	3, 3	3, 3	3, 3
Total Amps	5.2, 7.6	6.9, 7.6	5.5, 9.8
Defrost Amps	4.4	4.4	
10 ft. Cord/Plug [attached]	Yes (2)	Yes (2)	Yes (2)

SHIPPING DATA

WEIGHT (LBS.)	S2RFN	S3RRFN	S3RFFN
Weight (lbs.)	580	835	835
Height - Crated (in.)	85 1/2	85 1/2	85 1/2
Width - Crated (in.)	64	90	90
Depth - Crated (in.)	42	42	42

Ship Weight for -SA and -SS models is on average 5% higher than Standard models. Consult factory for shipping weight of these models.



Equipped with (1) 90° hospital grade NEMA-5-15P plug (varies by country)

LOCATION OF 1/2" DIAMETER PROBE ACCESS PORTS:

Consult factory for exact locations

Due to our continued efforts in developing innovative products, specifications subject to change without notice.

© Copyright 2021. Continental Refrigerator.
A Division of National Refrigeration & Air Conditioning Products, Inc.

