

GLASS DOOR LABORATORY/PHARMACY FREEZERS

Project Name:

Model Specified:

Location:

Item No:

Quantity:

Continental

SCIENTIFIC

539 Dunksferry Road
Bensalem, PA 19020
www.continentalscientific.com

Toll-Free: 800-523-7138
Phone: 215-244-1400
Fax: 215-244-9579

S1FNGD



S1FXNGD



Standard Model Features

REFRIGERATION SYSTEM

- Stainless steel front, aluminum end panels & interior
- Self contained, performance-rated refrigeration system
- Natural, environmentally-safe, high-efficiency R-290 refrigerant
- Automatic, electric condensate evaporator
- Automatic electric defrost

CABINET ARCHITECTURE

- 3" Non-CFC polyurethane foamed-in-place insulation
- Chrome-plated handles
- Heavy-duty epoxy-coated steel shelves
- Cylinder lock in each door
- Magnetic snap-in door gaskets
- (2) 1/2" diameter access ports
- Attached 10 ft. cord & 90° hospital grade NEMA-5-15P plug (For S1FNGD and S1FXNGD)
- Adjustable temperature control, range -22°C to -12°C, factory pre-set at -20°C
- 5" Casters

MODEL FEATURES

- LED interior lighting
- Electronic controller w/ centigrade temperature digital display

S2FNGD



Options and Accessories

(upcharges and lead times may apply)

Adjustable legs	220/50/1 Voltage
Additional shelves	208-230/60/1 Voltage
Pass thru doors (-PT models)	7 Day temperature chart recorder
Rehinging of doors	Remote temperature logger
Half doors (-HD models)	Audible/visual temperature alarm w/ battery back-up & dry contact relay
Stainless steel exterior, aluminum interior (-SA models)	Export crating
Stainless steel exterior and interior (-SS models)	NIST thermometer (consult factory)

S3FNGD



APPROVAL:

GLASS DOOR LABORATORY/PHARMACY FREEZERS

Line Drawings

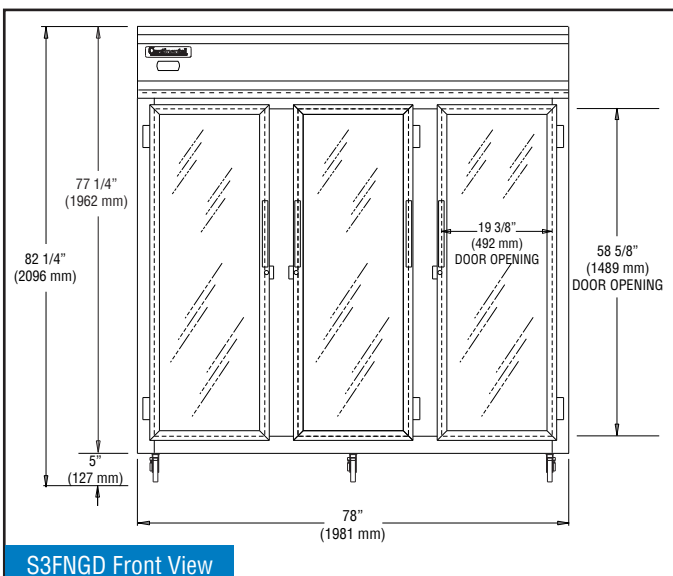
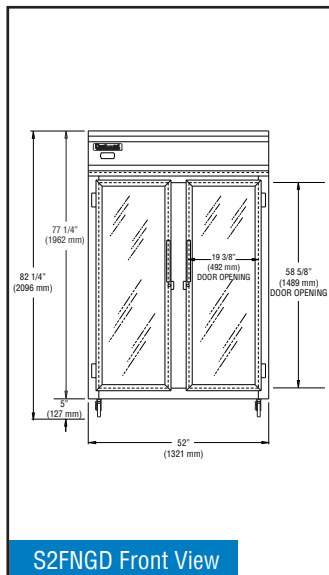
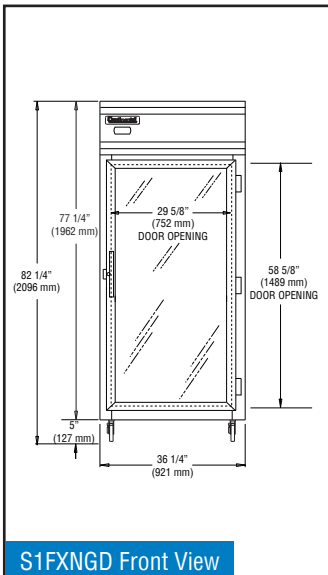
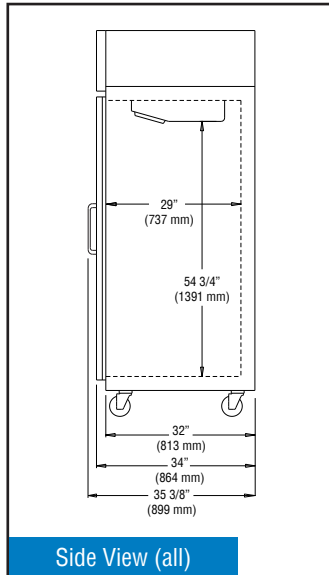
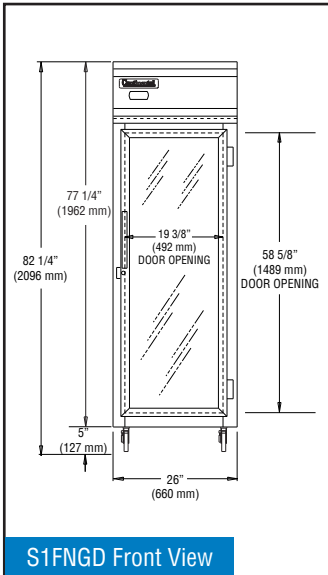

Continental

SCIENTIFIC

539 Dunksferry Road
Bensalem, PA 19020
www.continentalscientific.com

Toll-Free: 800-523-7138
Phone: 215-244-1400
Fax: 215-244-9579

Model Specifications

DIMENSIONAL DATA	S1FNGD	S1FXNGD	S2FNGD	S3FNGD
Net Capacity (cu. ft.)	20	30	48	70
Width, Overall (in.)	26	36 1/4	52	78
Depth, Overall (in.) (incl. handles & bumpers)	35 3/8	35 3/8	35 3/8	35 3/8
Height, Overall (in.)	82 1/4	82 1/4	85 3/4	85 3/4
No. of Doors	1	1	2	3
No. of Shelves	4	4	8	12
REFRIGERATION DATA				
Condensing Unit (H.P.)	1/2	1/2	1	1
ELECTRICAL DATA				
Voltage	115/60/1	115/60/1	115/208-230/60/1	115/208-230/60/1
Feed Wires (incl. ground)	3	3	4	4
Total Amps	8.2	9.4	12.4	14.7
10 ft. Cord/Plug [attached]	Yes	Yes	No	No
SHIPPING DATA				
Weight (lbs.)	330	455	565	805
Height - Crated (in.)	85 1/2	85 1/2	85 1/2	85 1/2
Width - Crated (in.)	31 5/8	42	64	90
Depth - Crated (in.)	42	42	42	42

Ship Weight for -SA and -SS models is on average 5% higher than Standard models. Consult factory for shipping weight of these models.



Equipped with (1) 90° hospital grade NEMA-5-15P plug (varies by country) (Excludes S2FNGD and S3FNGD models)

LOCATION OF 1/2" DIAMETER PROBE ACCESS PORTS:

- (1) Ceiling, front top left corner
 - (1) Rear wall, top center
- Consult factory for exact locations

Due to our continued efforts in developing innovative products, specifications subject to change without notice.

© Copyright 2021. Continental Refrigerator.
A Division of National Refrigeration & Air Conditioning Products, Inc.

